



# CFM500M Series

## Application Note V11

### 500W AC-DC Power Supply with PFC CFM500M Series APPLICATION NOTE



**Approved By:**

Department	Approved By	Checked By	Written By
Research and Development Department	Ovid	Yang	Joyce
Design Quality Department	Benny	JoJo	



# CFM500M Series

## Application Note V11

---

### Content

<b>1. INTRODUCTION</b>	<b>3</b>
<b>2. ELECTRICAL BLOCK DIAGRAM</b>	<b>3</b>
<b>3. MAIN FEATURES AND FUNCTIONS</b>	<b>4</b>
3.1 <i>Operating Temperature Range</i>	4
3.2 <i>Output Protection (Over Current Protection)</i>	4
<b>4. APPLICATIONS</b>	<b>4</b>
4.1 <i>Test Set-Up</i>	4
4.2 <i>Output Ripple and Noise Measurement</i>	4
4.3 <i>Installation Instruction</i>	5
4.4 <i>External Baseplate Cooling</i>	7
4.5 <i>PS On/Off Remote Control and Fan Control</i>	7
4.6 <i>Output Remote Sensing</i>	8
4.7 <i>EMI Test</i>	8
4.8 <i>Mating Connectors</i>	8
<b>5. PACKING INFORMATION</b>	<b>9</b>



# CFM500M Series

## Application Note V11

### 1. Introduction

This application note describes the features and functions of Cincon's CFM500M series of open frame, switching AC-DC power module. These are highly efficient, reliable, compact, high power density, single output AC/DC power modules. The module is fully protected against short circuit and over-voltage conditions. Cincon's world class automated manufacturing methods, together with an extensive testing and qualification program, ensure that the CFM500M series power module is extremely reliable.

### 2. Electrical Block Diagram

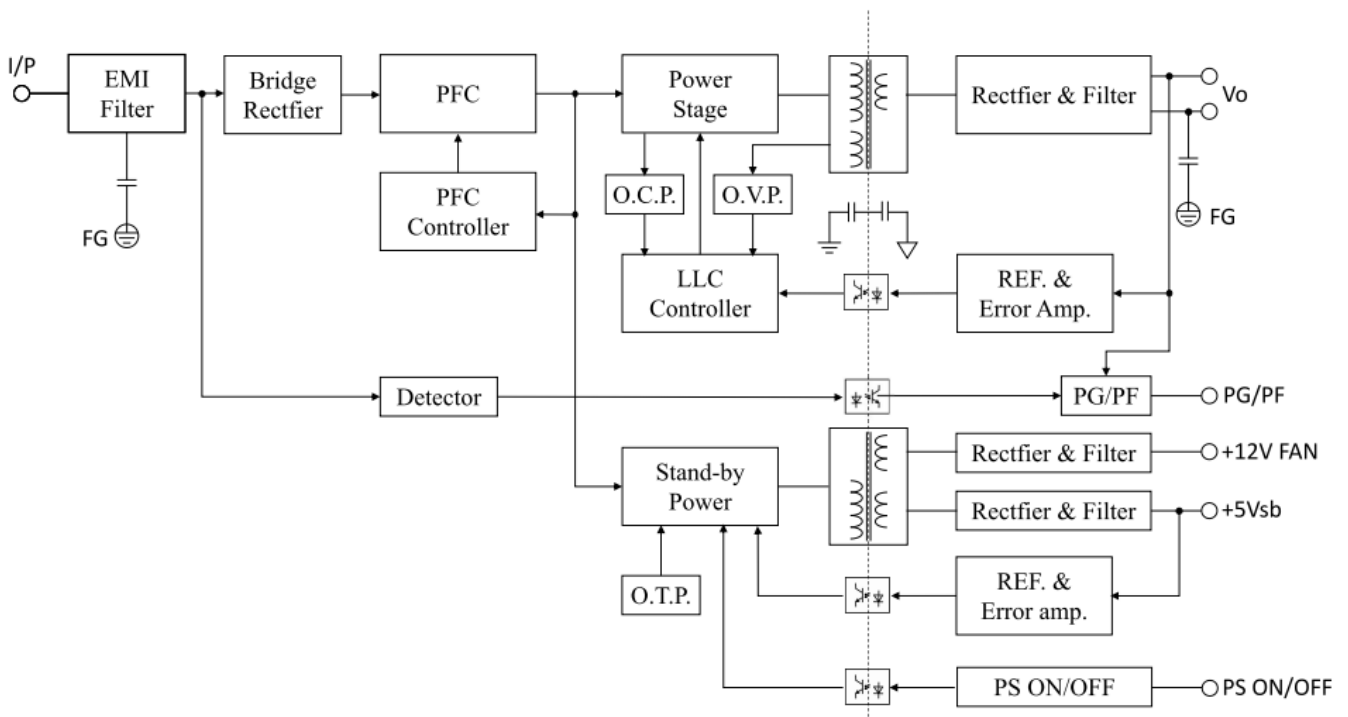



# CFM500M Series

## Application Note V11

### 3. Main Features and Functions

#### 3.1 Operating Temperature Range

The highly efficient design of Cincon's CFM500M series power modules has resulted in their ability to operate within ambient temperature environments from -40°C to 85°C. Due consideration must be given to the de-rating curves when ascertaining the maximum power that can be drawn from the module. The maximum power which can be drawn is influenced by a number of factors, such as

- Input voltage range
- Permissible output load (per derating curve)
- Effective heat sinks

#### 3.2 Output Protection (Over Current Protection)

The power modules provide full continuous short-circuit protection. The unit will auto recover once the short circuit is removed. To provide protection in a fault condition, the unit is equipped with internal over-current protection. The unit will operate normally once the fault condition is removed. The power module will go to hiccup mode if the output current is set from 110% to 180% of rated current.

### 4. Applications

#### 4.1 Test Set-Up

The basic test set-up to measure parameters such as efficiency and load regulation is shown in Figure 1. When testing the Cincon's CFM500M series under any transient conditions, please ensure that the transient response of the source is sufficient to power the equipment under test. We can calculate the

- Efficiency
- Load regulation and line regulation

The value of efficiency is defined as:

$$\eta = \frac{V_o \times I_o}{P_{in}} \times 100\%$$

Where:

- Vo is output voltage
- Io is output current
- Pin is input power

The value of load regulation is defined as:

$$Load\ reg. = \frac{V_{FL} - V_{NL}}{V_{NL}} \times 100\%$$

Where:

- V<sub>FL</sub> is the output voltage at full load
- V<sub>NL</sub> is the output voltage at 10% load

The value of line regulation is defined as:

$$Line\ reg. = \frac{V_{HL} - V_{LL}}{V_{LL}} \times 100\%$$

Where:

- V<sub>HL</sub> is the output voltage of maximum input voltage at full load.
- V<sub>LL</sub> is the output voltage of minimum input voltage at full load.

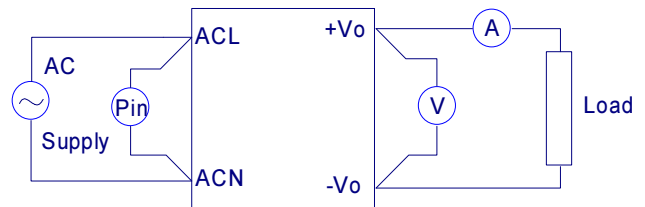

Figure 1. CFM500M Series Test Setup

#### 4.2 Output Ripple and Noise Measurement

The test set-up for noise and ripple measurements is shown in Figure 2. Measured method:

Add a C2=0.1uF ceramic capacitor and a C1=10uF electrolytic capacitor to output at 20 MHz Band Width.

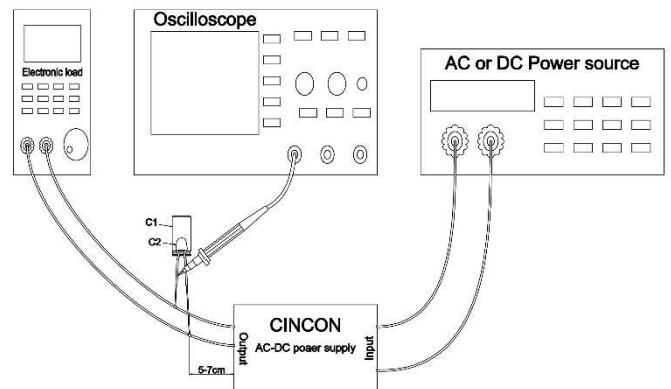

Figure 2. Output Voltage Ripple and Noise Measurement Set-Up



# CFM500M Series

## Application Note V11

### 4.3 Installation Instruction

The CFM500M series has four 4mm diameter mounting holes. There are three type installations for CFM500M. Please use the mounting holes as follows: Insert the spacer (4mm diameter max.) of 8mm height or more to mount the unit.

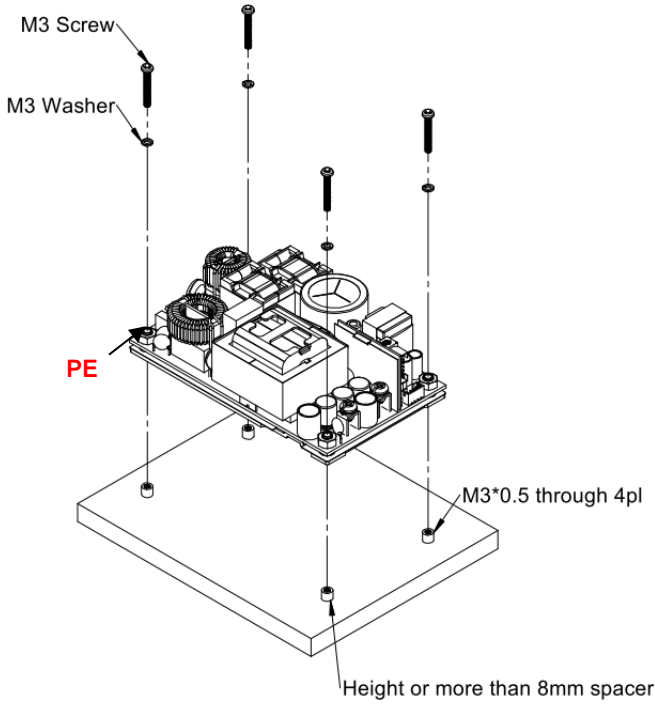

CFM500MXXX Installation Diagram

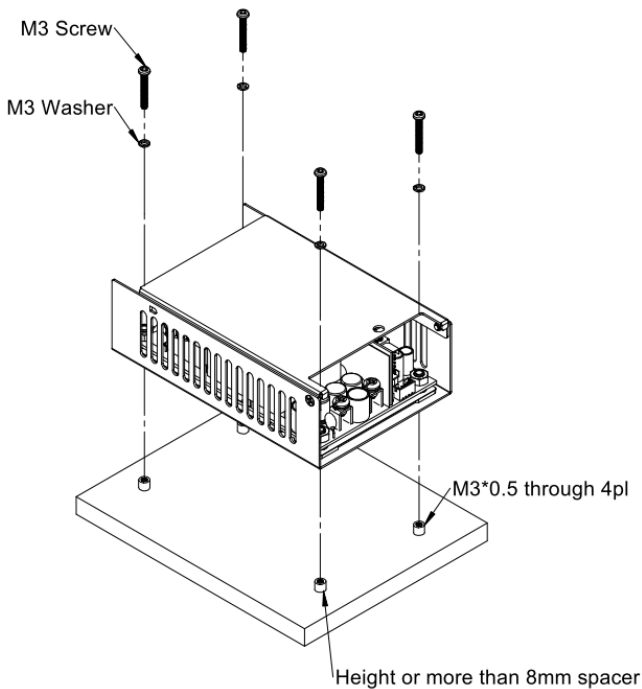

CFM500MXXXC Installation Diagram

The CFM500M series provide the baseplate cooling for customer to increasing heat dissipation. Please refer to the following figure for installation.

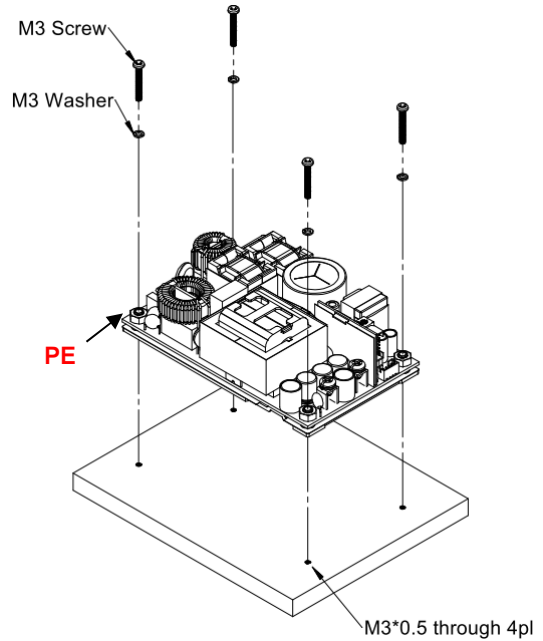

CFM500MXXX installation diagram

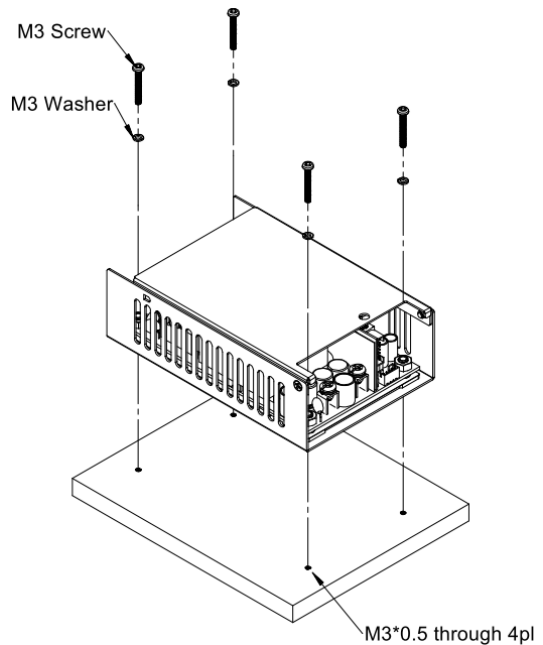

CFM500MXXXC installation diagram



# CFM500M Series

## Application Note V11

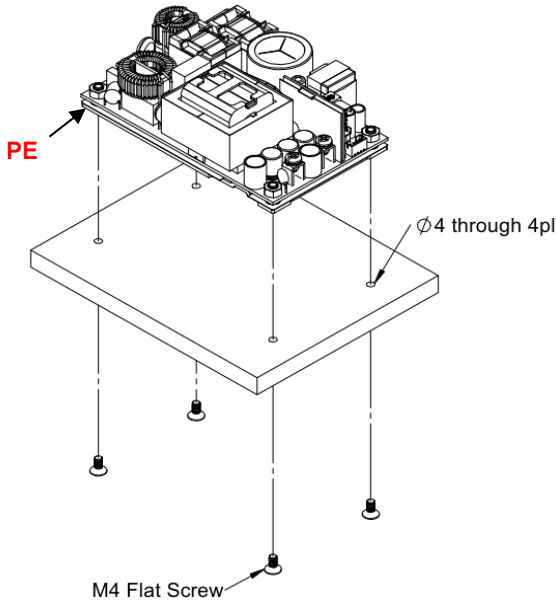

CFM500MXXX installation diagram

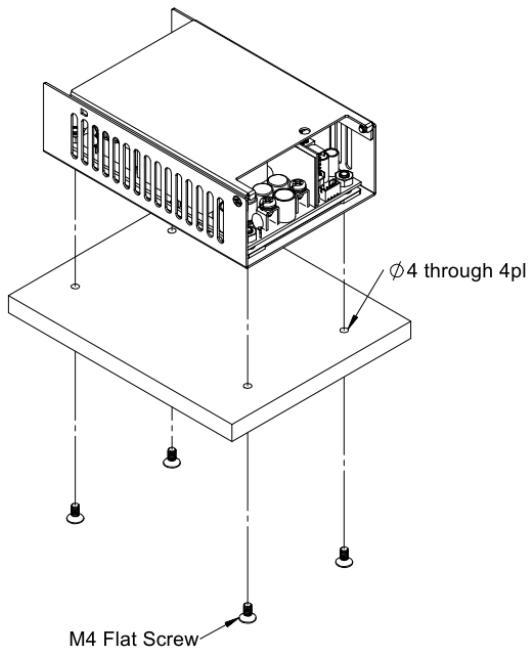

CFM500MXXXC installation diagram

Note: M3 & M4 screw head and washer diameter shall not exceed 5.5mm.

The torque of CFM500M series as follows:

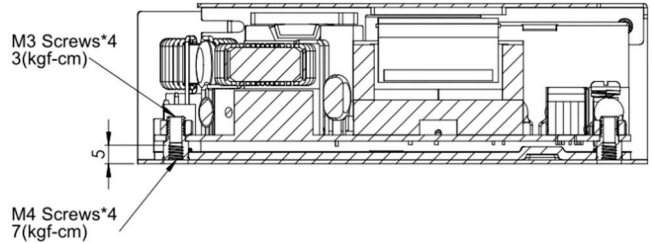
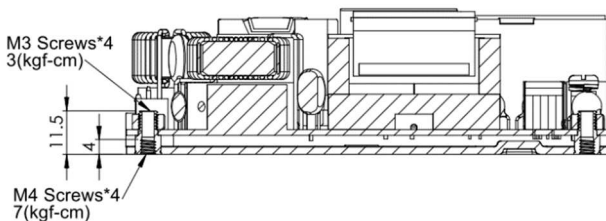

The torque of output connectors are 7kgf-cm and the connectors mate with round terminal. The maximum outer diameter of the terminal is 8.0mm and the maximum inner diameter is 4.3mm. When locking the round terminal or Y terminal to output connectors, the terminals should not touch other parts to avoid short.

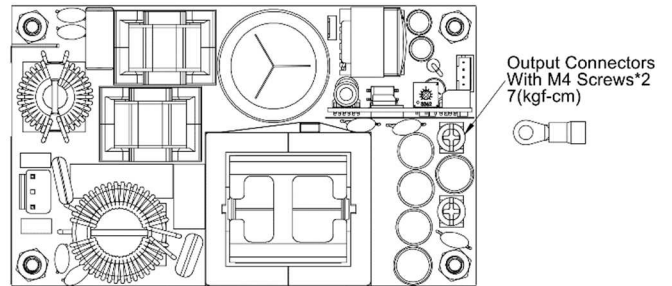

Please allow 4mm side clearance from the components and all side of the PCB. Allow 5mm clearance above the highest parts on the PCB. Be especially careful to allow 5mm between the solder side of the PCB and the mounting surface. If the clearances are not sufficient the specifications for isolation and withstand will not be valid.

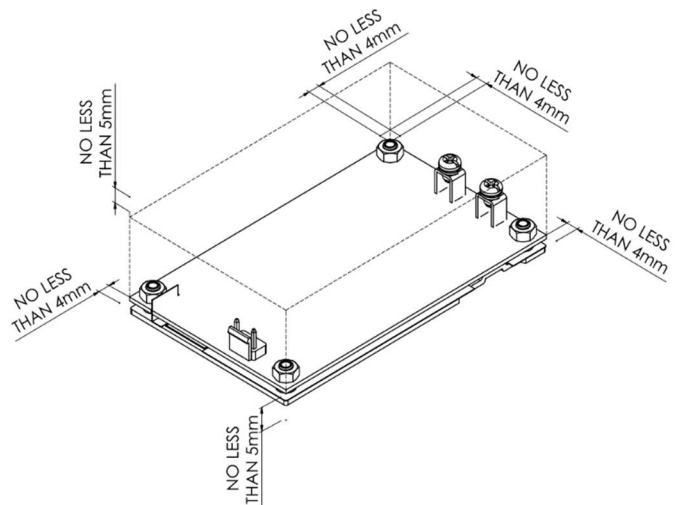

FG should be connected to the earth (ground) terminal of the apparatus. If not the conducted noise and output noise will increase.



# CFM500M Series

## Application Note V11

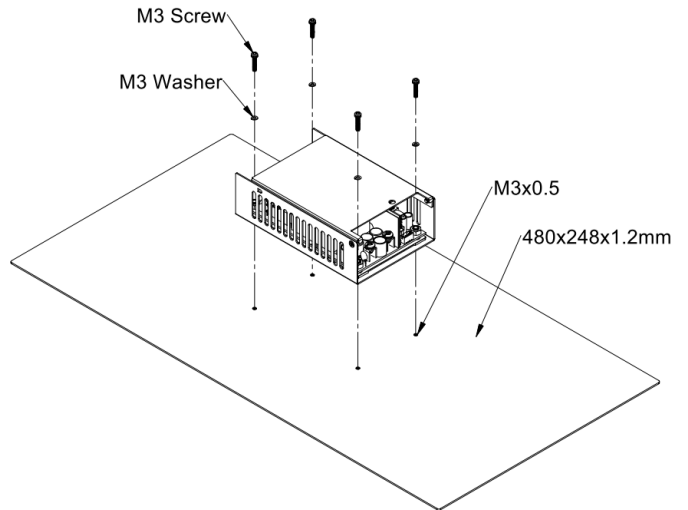
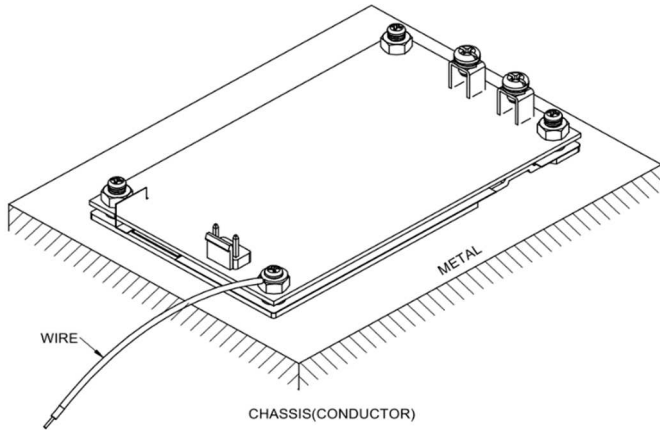

CFM500MXXXC installation diagram

### 4.4 External Baseplate Cooling

The CFM500M series provide the baseplate cooling for customer to increasing heat dissipation. For example, adding a 480mm\*248mm\*1.2mm heatsink at the bottom of CFM500M, between the heatsink and CFM500M with thermal grease to help heating ability. Please refer to the following figure for installation. When the CFM500M series uses an external baseplate cooling solution, it can be used at 470 ~ 500W. Please refer to the power derating curve in the specification.

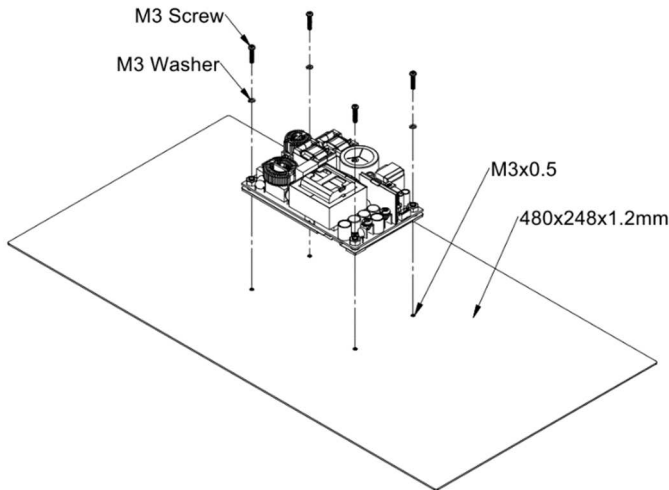

CFM500MXXX installation diagram

### 4.5 PS On/Off Remote Control and Fan Control

The PS-ON remote control is provided in CN3 pin 4. The diagram and control function are shown as follow:

Power On:  $V_{PS-ON} \leq 2V$ ,  $I_{PS-ON} \geq 10mA$  (PS-ON and GND short,  $I_{PS-ON} = 10mA$  typical).  
 Power Off: Open circuit,  $V_{PS-ON} = 4V$ .

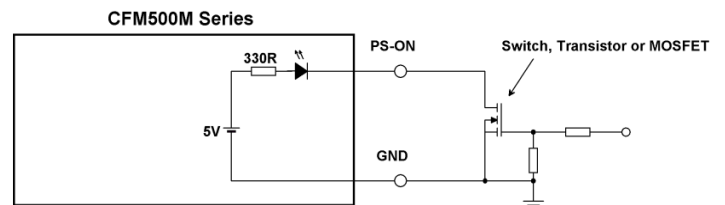

The fan control is provided in CN3 pin 3. The control function and diagram are shown as follow:

Fan On:  $V_{FAN-EN} \geq 1V$ .  
 Fan Off: Open circuit,  $V_{FAN-EN} = 0V$ .

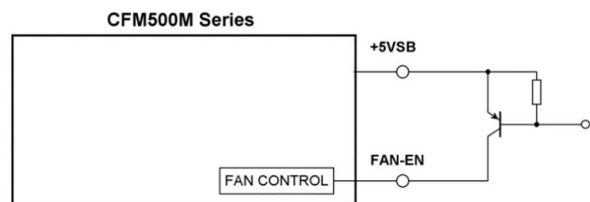

When the PS On/Off remote-control function is not used, connect a short circuit between the pin PS-ON and FAN-EN.



# CFM500M Series

## Application Note V11

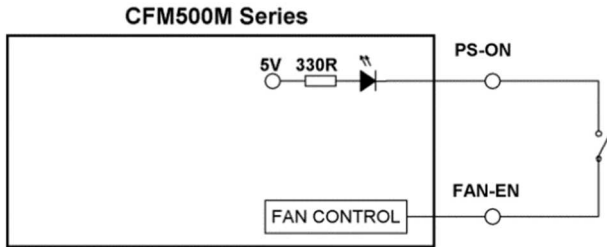

### 4.6 Output Remote Sensing

The CFM500M SERIES converter has the capability to remotely sense both lines of its output. This feature moves the effective output voltage regulation point from the output of the unit to the point of connection of the remote sense pins. This feature automatically adjusts the real output voltage of the CFM500M series in order to compensate for voltage drops in distribution and maintain a regulated voltage at the point of load. The remote-sense voltage range is:

$$[(+V_{out}) - (-V_{out})] - [(+Sense) - (-Sense)] \leq 5\% \text{ of } V_{o\_nominal}$$

If the remote sense feature is not to be used, the sense pins should be connected locally. The +Sense pin should be connected to the +Vout pin at the module and the -Sense pin should be connected to the -Vout pin at the module. A Remote Sensing is provided in CN3. This is shown in the schematic as below.

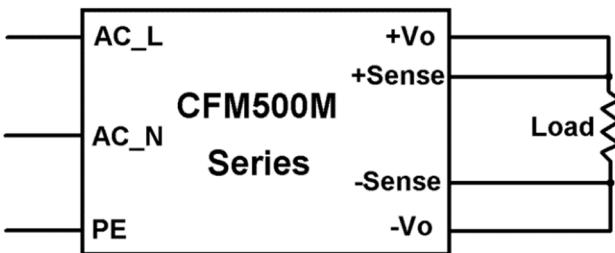

### 4.7 EMI Test

The CFM500M series Conductive EMI meets EN55011, FCC Part 15 Class B when test condition is Class I.

### 4.8 Mating Connectors

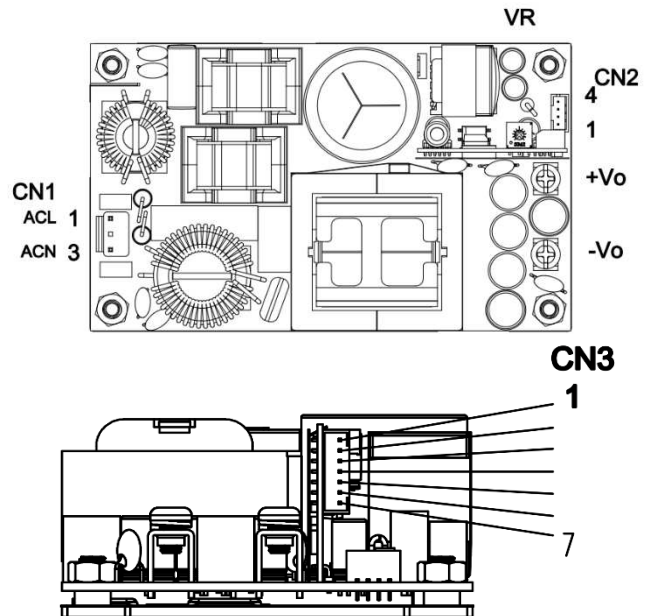

- CN1: Input connector wafer with JST VH series and mate with JST housing VHR series or equivalent. Optional Input connector wafer with LONG CHU P3161 series and mate with LONG CHU H3060 series or equivalent.
- CN2: Output connector wafer with TAIWAN KING PIN TERMINAL P110I series and mate with JST housing PH series or equivalent.
- CN3: Output connector wafer with JST PH series and mate with JST housing PH series or equivalent.
- Vo+ & Vo-: Output connectors mate with round terminal and round terminal of the max outer diameter is 8.0mm, max inner diameter is 4.3mm.





# CFM500M Series

## Application Note V11

### 5. Packing Information

The packing information for CFM500MXXX is showing as follows:

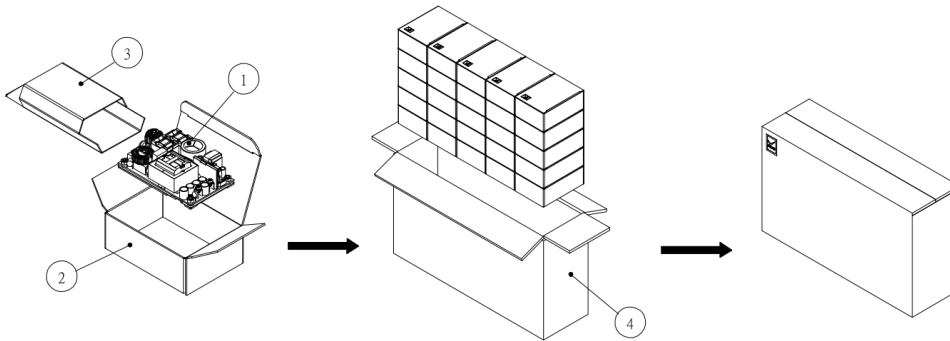

ITEM	PART NO.	NAME	OUTSIDE DIM(mm)	PCS
1		CFM500MXXX Product	127x76.2x39.1	25
2	G64205245	Inner Box	140x100x55	25
3	G64F00005	Antistatic Bag	(110+60)x165	25
4	G64112325	No.146 Cardboard Box	525x155x300	1

Each Box Packaging 25 PCS Products  
Gross weight Ref. 14.5 Kg

The packing information for CFM500MXXXC is showing as follows:

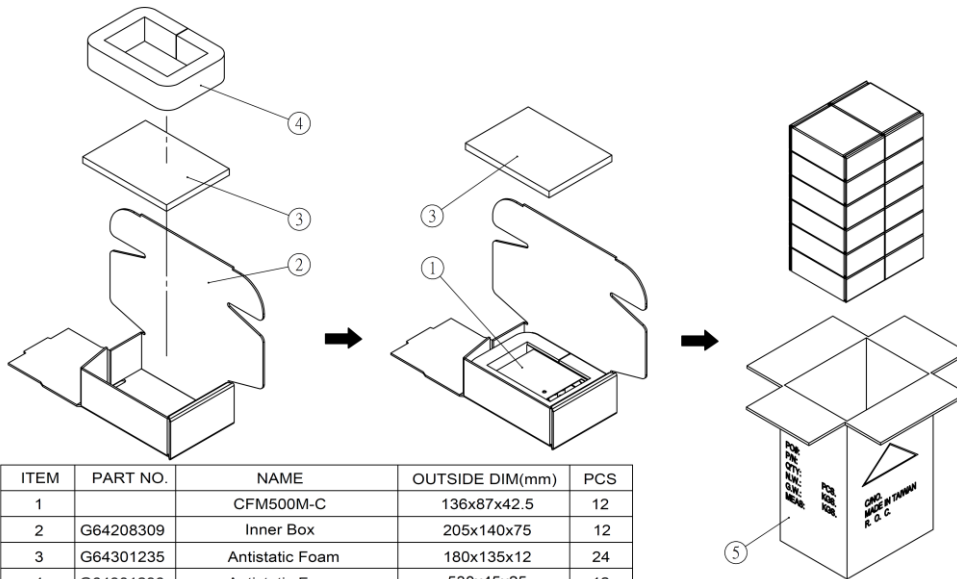

ITEM	PART NO.	NAME	OUTSIDE DIM(mm)	PCS
1		CFM500M-C	136x87x42.5	12
2	G64208309	Inner Box	205x140x75	12
3	G64301235	Antistatic Foam	180x135x12	24
4	G64301236	Antistatic Foam	530x45x25	12
5	G64100141	No.47 Cardboard Box	309.1x239.4x475.7	1

Each Box Packaging 12 PCS Products  
Gross weight Ref. 10 Kg

### CINCON ELECTRONICS CO., LTD.

#### Headquarters:

14F, No.306, Sec.4, Hsin Yi Rd.  
Taipei, Taiwan  
Tel: 886-2-27086210  
Fax: 886-2-27029852  
E-mail: [sales@cincon.com.tw](mailto:sales@cincon.com.tw)  
Web Site: <https://www.cincon.com>

#### Factory:

No. 8-1, Fu Kung Rd.  
Fu Hsing Industrial Park  
Fu Hsing Hsiang,  
Chang Hua Hsien, Taiwan  
Tel: 886-4-7690261  
Fax: 886-4-7698031

#### Cincon North America:

1655 Mesa Verde Ave. Ste 180  
Ventura, CA 93003  
Tel: 805-639-3350  
Fax: 805-639-4101  
E-mail: [info@cincon.com](mailto:info@cincon.com)